

# InterReach Fusion® SingleStar



ADC revolutionized the in-building wireless industry with InterReach Unison and it soon became the world standard. Yet today — with continued carrier consolidation, ever-changing spectrum allocation, and the unceasing bandwidth demand to meet voice and high-speed data requirements — the need for a true multi-band wireless solution has become paramount. That's where InterReach Fusion SingleStar comes in.

Fusion SingleStar offers all the benefits of Unison Accel in a multi-band solution, enabling any organization to implement state-of-the-art in-building wireless for areas between 100,000 square feet (10,000 square meters) and 350,000 square feet (33,000 square meters). Highly economical and remarkably easy to maintain, Fusion SingleStar delivers unparalleled high performance that competitive products simply cannot match. There are even integrated Web-based administrative and maintenance tools.

Fusion SingleStar's advanced configuration options are ideal for wireless operators who deploy multi-band spectrum in-building solutions as well as for multi-operator installations such as public venues (hotels, retail shops, subway stations) and enterprises.

## InterReach Fusion SingleStar Features:

- Delivers wireless voice and high speed data
- True multi-band system using a single set of electronics/cabling
- Supports frequencies from 800MHz to 2100MHz
- Dedicated capacity per band, easily supports dense user environments
- Distributed amplifier system, ensuring best-in-class performance and uniform output power at every antenna point
- High output power, provides greater coverage area per antenna
- Zero loss system, making design simple and guaranteeing consistent coverage from every antenna
- Economical installation thanks to use of CATV cabling
- Simple singlestar architecture makes installation and future expansion quick and nondisruptive
- Best-in-class integrated Web-based administrative and maintenance tools
- Integrated SNMP capability allows use of standard network management packages
- FCC, UL and CE Mark approved

PRODUCT HIGHLIGHTS





# InterReach Fusion® SingleStar

Advantages of the InterReach Fusion SingleStar system include:

- True multi-band system with a variety of multi-frequency, full band, protocol independent configuration options
- Industry-leading RF performance, with high output power and dedicated capacity per band
- Simple, economical installation using broadband CATV cabling. Flexible, quick to install, easy to connectorize, can span from 500 to 1000 feet (150 to 300 meters), and doesn't require specialized installers
- Integrated Web-based administration and maintenance tools, featuring easy to navigate GUI
- Integrated SNMP capability enables use of standard network management packages for remote monitoring

## Components

InterReach Fusion SingleStar features an easy-to-deploy hub and spoke architecture with just two types of components: a Hub that connects via CATV cabling to up to eight Remote Access Units (RAUs). The SingleStar Hub receives its radio frequency (RF) signal from a base station, a MetroReach Focus system, or a repeater. The Hub electrically distributes the signal to the RAUs via CATV (thin Ethernet) cabling. Each RAU converts the signal to RF and sends — and receives — the signals via antennas connected to the RAU to the wireless phones and PDAs located within its coverage area. The SingleStar hub is packaged in a 19" rack-mountable unit. The small RAUs, and the antennas connected to them, are typically mounted in ceiling spaces throughout the facility. The CATV cabling between the hub and each of the eight RAUs can be up to 300 meters (1000 feet) long depending on the cable type used. RG59, RG6, and RG11 cable types can all be used with the system.

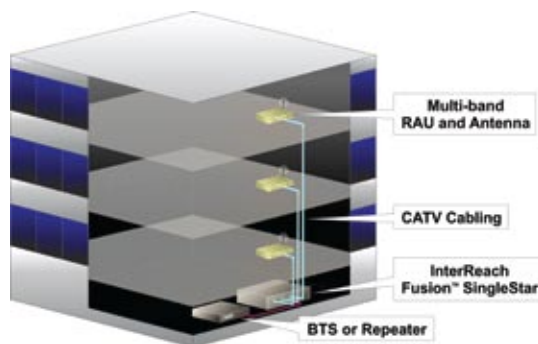

3/09 • 106091AE InterReach Fusion SingleStar®



# InterReach Fusion<sup>®</sup> SingleStar

3 / 0 9 • 1 0 6 0 9 1 A E InterReach Fusion SingleStar<sup>®</sup>

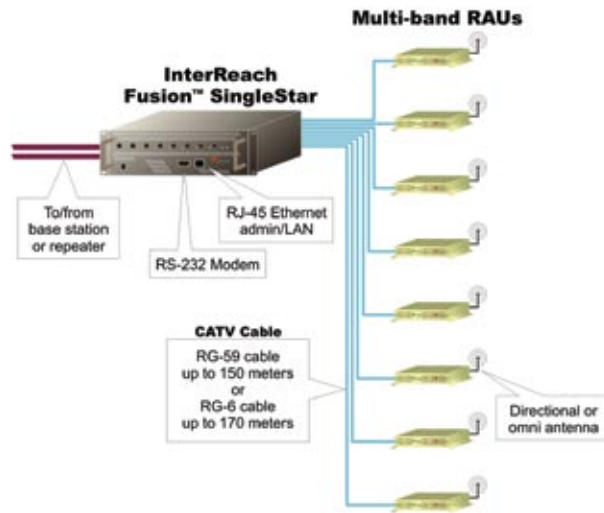

## Protocols

Fusion SingleStar was designed with a variety of multi-frequency (from 800 MHz to 2.1 GHz), full-band, protocol-independent configuration options to support any environment, anywhere.

And unlike competing solutions, Fusion SingleStar offers dedicated capacity per band. Other solutions provide a fixed amount of capacity shared across bands, forcing unwelcome trade-offs when adding capacity to a specific band.

Fusion's advanced configuration options are ideal for wireless operators who deploy multi-band spectrum in-building solutions as well as for multi-operator installations such as public venues (airports, resorts/hotels, shopping malls, sports venues, convention centers) and enterprises.

## Ease of Installation

Fusion leads the industry in ROI by requiring less equipment and less cabling, and that translates into low installation costs, resulting in the lowest total solution cost. Cost efficient broadband CATV cabling is utilized between the hub and the remote access unit. The inexpensive CATV cabling used is less than a 1/4" in diameter, flexible, quick to install, easy to connectorize, and can span from 150 to 300 meters depending on the type deployed. And different CATV cable types can be "mixed and matched" on a single hub to easily accommodate varying cable run length requirements. Plus, it doesn't require specialized installers, another great savings. The system's singlestar architecture not only makes installation easy, it also makes accommodating future growth a snap. In most instances, there's no need to add lots of additional equipment and cabling to expand system coverage – it's as easy as simply adding another CATV cable and antenna point on the system. Likewise, adding capacity doesn't require system rebalancing or more equipment thanks to Fusion SingleStar's high composite power and dedicated capacity per band. And that simplicity holds true for adding support for additional wireless operators or newly acquired spectrum.

## Management Tools

ADC understands that after the installation, sophisticated systems management is critical for providing continuous wireless service and maximum “up-time”. To meet these requirements, ADC provides a comprehensive and flexible set of system management solutions and services. With InterReach Fusion products, day-to-day operations are simple, straightforward, and cost effective thanks to a Web-based configuration and maintenance capability. No proprietary software is needed, as any standard Internet browser can access the integrated Web server, and that makes local and/or remote routine maintenance and troubleshooting a seamless undertaking. Also, the resident SNMP capability supports connectivity to any standard network management package, so customers can easily integrate Fusion management into their existing network operations.

ADC’s InterReach Fusion in-building wireless systems continuously monitor over 60 parameters including both system components and cable infrastructure. Should a fault condition develop, InterReach Fusion proactively sends notification via one of several methods:

- Alarm contacts connected to a basestation that is monitored by the wireless operators’ network management system
- SNMP traps to an SNMP Network Management System (NMS) via Ethernet LAN or modem outcalling
- Monitoring adds value in that it regularly confirms that the connections to the InterReach Fusion system are operational and available and that there are no issues with the systems. Remote monitoring can be done by the wireless operator, the enterprise, or ADC’s Network Operations Center.

PRODUCT HIGHLIGHTS



### **Website: [www.adc.com](http://www.adc.com)**

From North America, Call Toll Free: 1-800-366-3891 • Outside of North America: +1-952-938-8080

Fax: +1-952-917-3237 • For a listing of ADC’s global sales office locations, please refer to our website.

ADC Telecommunications, Inc., P.O. Box 1101, Minneapolis, Minnesota USA 55440-1101

Specifications published here are current as of the date of publication of this document. Because we are continuously improving our products, ADC reserves the right to change specifications without prior notice. At any time, you may verify product specifications by contacting our headquarters office in Minneapolis. ADC Telecommunications, Inc. views its patent portfolio as an important corporate asset and vigorously enforces its patents. Products or features contained herein may be covered by one or more U.S. or foreign patents. An Equal Opportunity Employer

**106091AE 3/09 Revision © 2009, 2008 ADC Telecommunications, Inc. All Rights Reserved**